

# TX-RV

Self centering  
Rigid jaws

## Quick jaw change, high precision pull-down chucks

Ø 210 - 530 mm

- active pull-down
- quick jaw change (internal/external)
- 3 jaws



### Application/customer benefits

- Clamping of workpieces with highest demand for **parallelism**
- **Highest productivity** with long maintenance intervals
- For small-medium batches production, due to the quick jaw change
- All chucks are the same, the same jaws can be used on all chucks of the same size
- Constant grip force and long lifetime ensure **constant quality of work pieces**

### Technical features

- 3-jaw-design
- active pull-down
- centrifugal force compensation
- tongue & groove base jaws
- central bore for coolant and/or air
- permanent oil lubrication
- **proofline® chucks** = fully sealed – low maintenance

### Standard equipment

3-jaw-chuck  
Mounting bolts and grease gun

### Ordering example

3-jaw-chuck TX-RV 530/A11

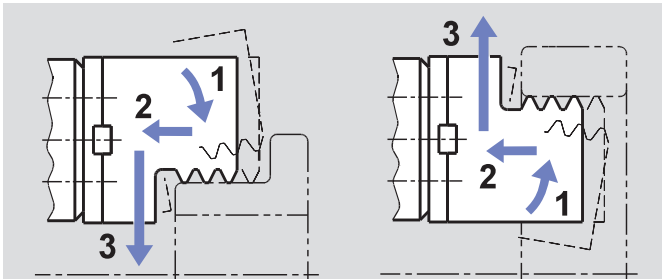

Principle of function:

- 1 pre-clamping - 2 active pull-down - 3 clamping
- For O.D. and I.D. clamping

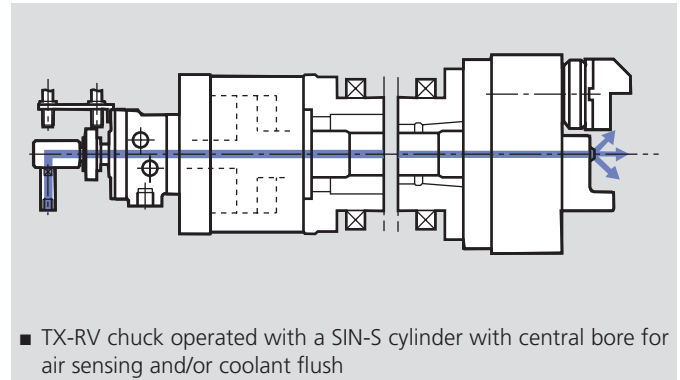

- TX-RV chuck operated with a SIN-S cylinder with central bore for air sensing and/or coolant flush

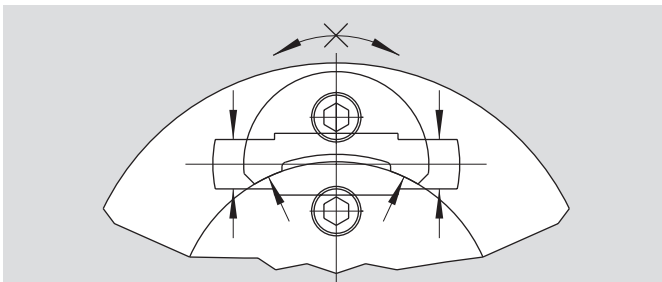

**TX-RV:** High resistance to the radial torque, ideal for turning and milling application and guarantee of high precision, durability and constant process results

## Technical data

SMW-AUTOBLOK Type		TX-RV 210	TX-RV 250	TX-RV 315	TX-RV 400	TX-RV 530
Angular jaw stroke	deg.	5.2°	4.9°	4.9°	4.7°	4.7°
Radial jaw stroke at distance h	mm	6.3	7	7	7.5	7.5
Pull down movement (standard)	mm	0.1	0.1	0.1	0.2	0.2
Axial piston stroke	mm	25	26	26	30	30
Max. draw pull	kN	25	40	40	50	60
Max. gripping force at distance h	kN	60	96	96	120	150
Max. speed*	r.p.m.	4500	3800	3000	2200	1800
Mass (plain back without top jaws)	kg	28	42	67	125	248
Moment of inertia (m·r <sup>2</sup> )	kg·m <sup>2</sup>	0.17	0.35	0.84	2.3	8.8
Recommended actuating cylinders		SIN-S 100	SIN-S 125	SIN-S 125	SIN-S 150	SIN-S 150

\* The above maximum speed is allowed with standard weight/height top jaws and applying the full draw pull only. For more informations please contact SMW-AUTOBLOK.



on request:  
Tooling Standard  
Parts Catalog

Page 310

Page 304

Page 217

# Quick jaw change, high precision pull-down chucks

Ø 210 - 530 mm

- active pull-down
- quick jaw change (internal/external)
- 3 jaws

# TX-RV

Self centering  
Rigid jaws

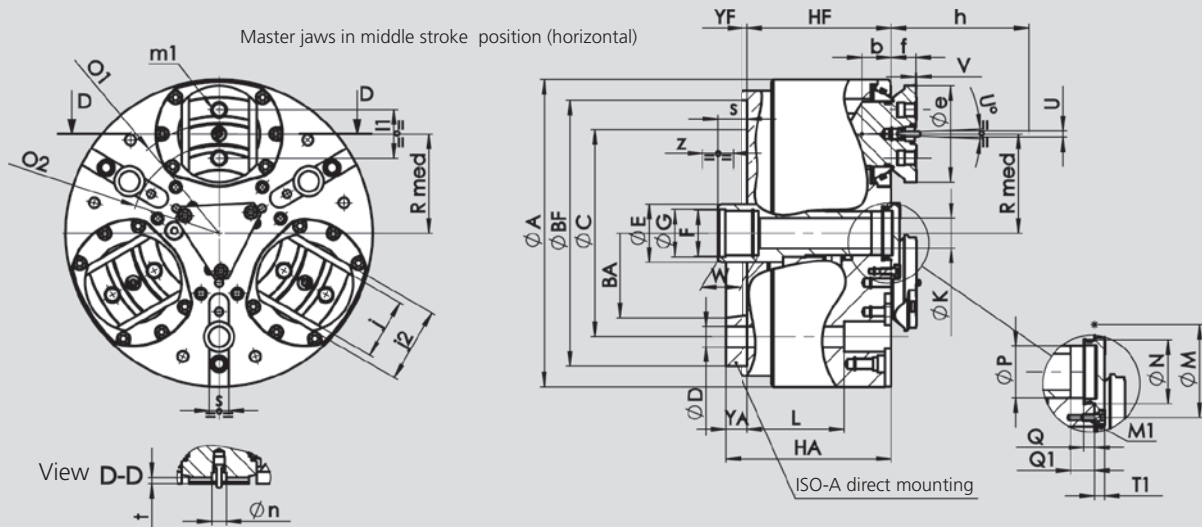

Subject to technical changes  
For more detailed information please ask for customer drawing

4

SMW-AUTOBLOK	Type		TX-RV 210		TX-RV 250		TX-RV 315		TX-RV 400		TX-RV 530	
Mounting			Z170	A6	Z220	A8	Z220	A8	Z300	A11	Z380	A11
	<b>A</b>	mm	212		254		315		390		535	
	<b>Bf/BA</b>	H6 mm	170	106.375	220	139.719	220	139.719	300	196.869	380	285.775
	<b>C</b>	mm	133.4		171.4		171.4		235		330.2	
	<b>D</b>	mm	13.5		17		17		21		25	
	<b>E</b>	mm	38		48		48		75		75	
	<b>F</b>	mm	M32 x 1.5		M38 x 1.5		M38 x 1.5		M60 x 1.5		M60 x 1.5	
	<b>G</b>	H8 mm	33		39		39		61		61	
	<b>Hf/HA</b>	mm	112	129	119	138	119	138	144	165	149	172
Through-hole	<b>K</b>	mm	18		25		25		52		52	
	<b>L</b>	mm	82		80		80		94		97	
	<b>M</b>	mm	42		63		63		90		90	
Thread/depth	<b>M1</b>	mm	M6/11		M6/14		M6/14		M8/18		M8/18	
	<b>N</b>	H8 mm	34		44		44		75		75	
	<b>P</b>	mm	28		36		36		65		65	
	<b>Q</b>	mm	5.5		7.5		7.5		9		9	
At middle stroke	<b>Q1</b>	mm	14		16		16		21		21	
At middle stroke	<b>Rmed</b>	mm	64		82		107		130		190	
At middle stroke	<b>S</b>	mm	20		25		25		25		21	
	<b>s</b>	mm	16		16		16		-		-	
	<b>T1</b>	mm	7		7		7		15		15	
Radial stroke°	<b>U°</b>	deg.	5.2°		4.9°		4.9°		4.7°		4.7°	
Radial stroke (1)	<b>U</b>	mm	6.3		7		7		7.5		7.5	
Pull-down s/d	<b>V</b>	mm	0.1		0.1		0.1		0.2		0.2	
	<b>W</b>	mm	25		30		30		34		34	
Axial piston stroke	<b>Z</b>	mm	25		26		26		30		30	
	<b>e</b>	mm	75		80		80		105		105	
	<b>f</b>	mm	21		21		21		28		28	
Reference height	<b>h</b>	mm	48		58		58		63		63	
	<b>j</b>	mm	45		50		50		70		70	
	<b>l1</b>	mm	36		40		40		52		52	
Thread/depth	<b>m1</b>	mm	M12/15		M12/15		M12/15		M16/18		M16/18	
	<b>n</b>	h8 mm	12		12		12		12		12	
	<b>o1</b>	js6 mm	142		180		230		276		396	
	<b>O2</b>	js6 mm	114		148		198		244		364	
	<b>s</b>	mm	16		16		16		16		16	
	<b>t</b>	mm	5		5		5		6		6	
	<b>Yf</b>	mm	5		5		5		6		6	

(1) Calculated at **h** distance from the chuck's face